

MAGICOOL

Magicool® MC-RADI280 Dual 140 mm Slim Radiator

As a professional OEM manufacturer in Computer liquid cooling area, Magicool®'s product line covers all liquid cooling components, especially different size of heat exchangers, water tanks, pumps, cooling blocks and accessories. Excellent price-performance ratio and reliable quality make Magicool® products unique.

With their compact design and top cooling performance, the Magicool® radiators become the favorite high-end heat exchangers. The copper fins are especially designed for silent fans, while the parallel coolant channels reduce liquid resistance to a minimum achieving the best performance with the minimum noise. On both sides of the radiator M3 threads are integrated to allow flexible fan mounting, and the integrated G1/4" threads allow easy installation of all common fittings and bars.



Copper fins – optimized for low speed fans



Most compatibility – Standard G 1/4" thread

Section Drawing

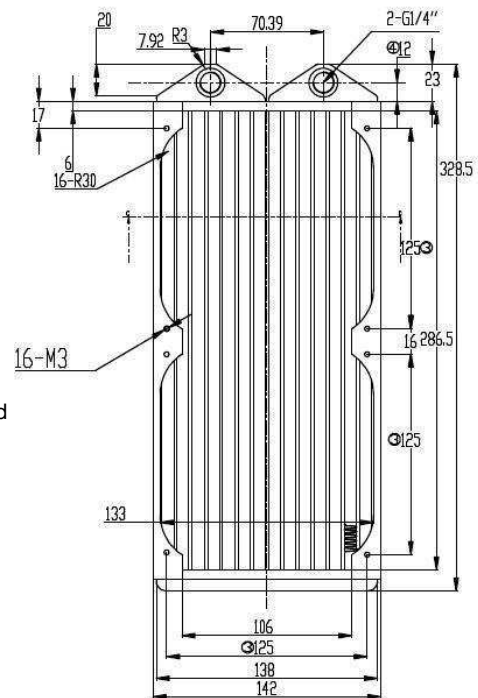

Features:

- Dual pass radiator designed for Computer liquid cooling.
- High liquid and air flow design, copper fin spacing optimized for silent fans
- Spray painting on copper fins for enhanced heat transfer.
- M3 fan mounting holes for easy installation on both sides.
- Compact 323 x 145 x 29 (mm) size for easy mounting in mid tower case.

Specifications

Material	: Copper fins and tubes, brass chambers
Tube (L x W)	: 19 x 2 mm
Fins spacing	: 14 FPI (Fins Per Inch)
Dimensions (L x W x H)	: 323 x 145 x 29 mm
Connection port:	: G 1/4"
Weight approx	: 710 g
Fan installation	: 8 pcs. M3 threads on both sides each (for 2 x 140 mm fan each)
Pressure tested	: 2.5 bar

Delivery includes

1x Dual 140 mm Slim radiator
 1x Retail colour box
 8x 30 mm screws
 8x 35 mm screws
 2x Silicon pads