

MC-DCP450 - Magicool DC 12V Pump

As a professional OEM manufacturer in Computer liquid cooling area, Magicool®'s product line covers all liquid cooling components, especially different size of heat exchangers, water tanks, pumps, cooling blocks and accessories. Excellent price-performance ratio and reliable quality make Magicool® products unique.

Magicool® DCP 450 Pump has an integrated reservoir. With its 2,4 m pump height and 450 L/Hr. pump speed it is a perfect powerful but silent pump for computer liquid cooling. The G 1/4" fitting threads provides compatibility with most of the water cooling systems on market and along with the G 1/4" filling port this pump makes the water cooling setup extremely convenient.

Features:

- Extreme silent and low power consumption
- 3 phase motor with ceramic bearing
- Compact pump with integrated water tank
- SATA powered with 3 pin monitoring function
- Inclusive holder and fill port

MAGICOOL



Specifications

Technical specifications:

Motor: 3 phase motor, ceramic bearing
Power input : DC 12 V SATA, 6 W
Monitoring: 3 pin connector for M/B
Material : Fiber Glass Nylon top/bottom/holders, Acryl tube
Water capacity : 250 ml
Dimensions : 70 (D) x 135 (H) (mm)
Pump speed: 450 l/hr., Pump height: 2,4 m
Filling port, In- and Outlet : G1/4"
Weight: 400 g; Life time: 50,000 hrs.

Product category:
DC 12V Pump

Caution:
Pump reservoir is made of Acryl, don't use alcohol or its derivatives, which could cause Acryl break.

Please pay attention to marked "IN" and "OUT" on the CPU top cover and connect with other components accordingly.



Pump holders with HDD cage brackets



SATA power with 3 pin monitoring

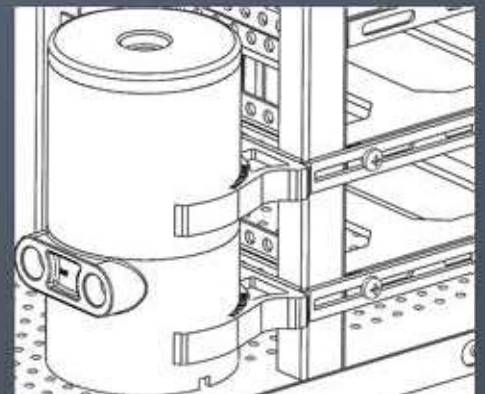

Pump installation example